

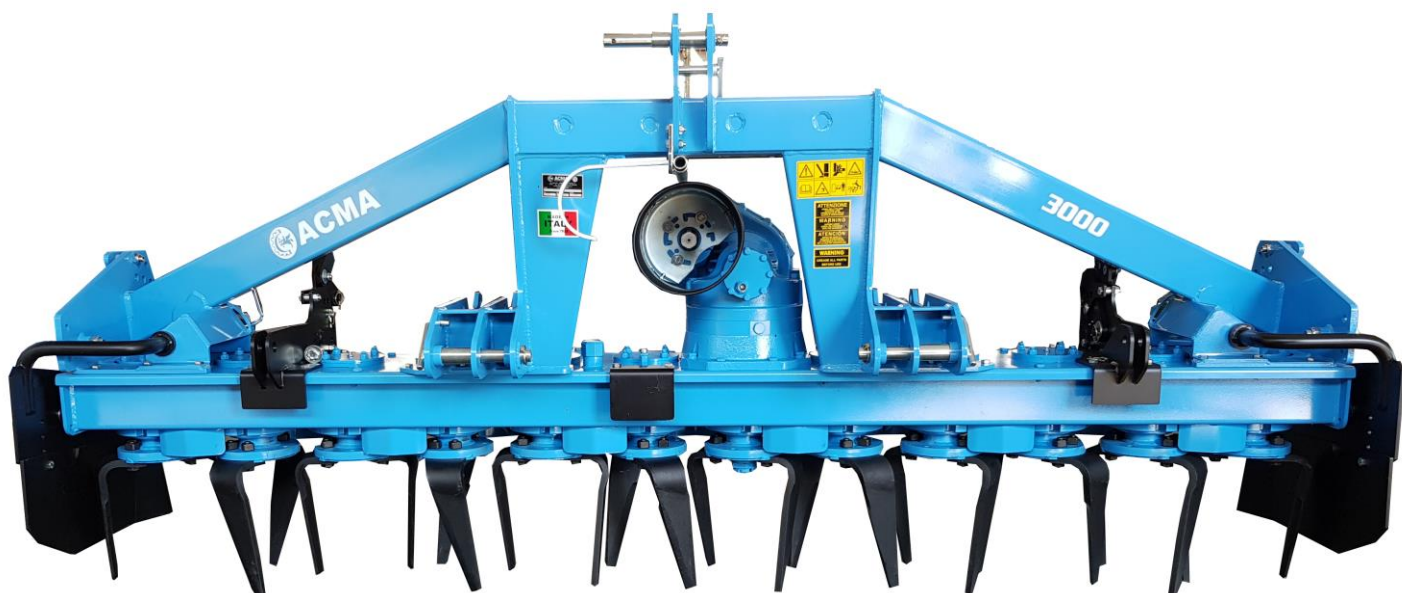

Gamma ERPICI ROTANTI



POWER HARROWS Range
Gama GRADAS ROTATIVAS
KREISELEGGEN Reichweite





IT-EN-ES-TE

model E

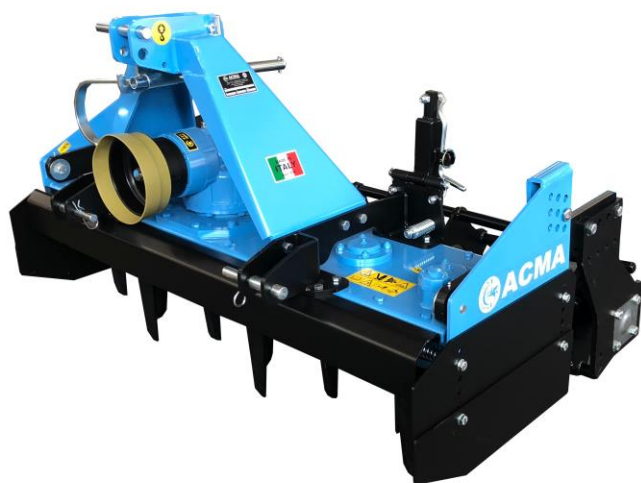
25-100 HP

- Riduttore mono-velocità
- Barra livellatrice posteriore
- Albero portadenti in acciaio
- Fiancate laterali oscillanti
- Single speed gearbox
- Rear levelling bar
- Steel tooth shaft
- Tilting side panel
- Reductor de velocidad simple
- Barra de nivelación trasera
- Eje del diente de acero
- Vial lateral oscilante
- Ein Geschwindigkeitsreduzierer
- Stahlzahnwelle
- Riduttore mono-velocità
- Oszillierende Seitenfläschchen
- Protezioni antinfortunistiche CE
- Parasassi anteriore e parapietre richiesta
- Regolazione rapida rullo posteriore
- Larghezze lavoro da 1 a 2,5 metri
- CE safety guards
- Front and rear stone guard required
- Rear roller quick adjustment
- Working widths from 1 to 2.5 meters
- Guardias de seguridad CE
- Se requieren barandillas delanteras y de piedra
- Ajuste rápido del rodillo trasero
- Anchuras de trabajo desde 1 hasta 2,5 metros
- CE-Schutzvorrichtungen
- Vorderer und hinterer Steinschutz erforderlich
- Hintere Rollenschnelleinstellung
- Arbeitsbreiten von 1 bis 2,5 Metern



MODEL	 cm	 HP	 540 g/min 1000		 n°	 cm	 Kg	 Kg	 Kg
E100L	100	25-35	279	518	4	23	420	430	
E125L	125	35-45	279	518	5	23	470	500	
E150L	150	40-45	279	518	6	23	530	550	
E180L	180	45-50	279	518	7	25	560	575	660
E200L	200	50-60	279	518	8	25	590	600	730
E225L	225	60-70	279	518	9	25	610	620	790
E250L	250	70-100	279	518	10	25	520	630	850

model R





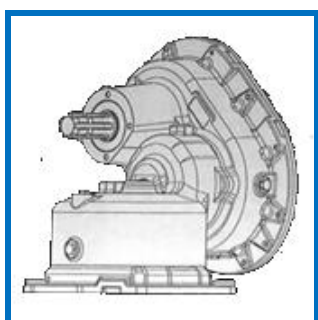



60-160 HP

- Barra livellatrice posteriore
- Parasassi anteriore e parapietre richiesta
- Rear levelling bar
- Front and rear stone guard required
- Barra de nivelación trasera
- Se requieren barandillas delanteras y de piedra
- Stahlzahnwelle
- Vorderer und hintere Steinschutz erforderlich
- Fiancate laterali oscillanti
- Larghezze di lavoro da 2,25 a 3 metri
- Tilting side panel
- Working widths from 2,25 to 3 meters
- Vial lateral oscillante
- Anchuras de trabajo desde 2,25 hasta 3 metros
- Hintere Rollenschnelleinstellung
- Arbeitsbreiten von 2,25 bis 3 Metern



Cambio di velocità
Speed change
Cambio de velocidad
Geschwindigkeitsänderung



MODEL	 cm	 HP	 540 g/min 1000		 n°	 cm	 Kg	 Kg	 Kg
R225S	225	60-90	221	305	9	25	850	860	980
R250S	250	70-130	221	305	10	25	900	920	1050
R300S	300	100-160	221	305	12	25	1000	1000	1150

model S









100-220 HP

- Barra livellatrice posteriore
- Parasassi anteriore e parapietre richiesta
- Rear levelling bar
- Front and rear stone guard required
- Barra de nivelación trasera
- Se requieren barandillas delanteras y de piedra
- Stahlzahnwelle
- Vorderer und hintere Steinschutz erforderlich
- Fiancate laterali oscillanti, cambio di velocità
- Larghezze di lavoro da 2,50 a 4 metri
- Tilting side panel, speed change
- Working widths from 2,50 to 4 meters
- Vial lateral oscilante, cambio de velocidad
- Anchuras de trabajo desde 2,50 hasta 4 metros
- Hintere Rollenschnelleinstellung, Geschwindigkeit
- Arbeitsbreiten von 2,50 bis 4 Metern

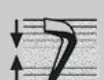

- BANDELLA LATERALE e PARAPIETRE
- SIDE PANEL and STONE GUARD
- VIAL LATERAL y PIEDRA PROTECTION
- ROLLENSCHNELLEINSTELLUNG



MODEL	 cm	 HP	 540 g/min 1000	 n°	 cm	 Kg	 Kg	 Kg	
S250M	250	100-130	221/305	410	10	27	1120	1140	1300
S300M	300	120-160	221/305	410	12	27	1250	1280	1560
S350M	350	140-200	221/305	410	14	27	1370	1390	1670
S400M	400	160-220	221/305	410	16	27	1470	1550	1850

model K







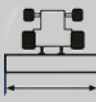

130-260 HP

- Barra livellatrice posteriore
- Parasassi anteriore e parapietre richiesta
- Rear levelling bar
- Front and rear stone guard required
- Barra de nivelación trasera
- Se requieren barandillas delanteras y de piedra
- Stahlzahnwelle
- Vorderer und hintere Steinschutz erforderlich
- Fiancate laterali oscillanti
- Larghezze di lavoro da 3 a 4 metri
- Tilting side panel
- Working widths from 3 to 4 meters
- Vial laterale oscillante
- Anchuras de trabajo desde 3 hasta 4 metros
- Hintere Rollenschnelleinstellung
- Arbeitsbreiten von 3 bis 4 Metern



Sgancio rapido coltelli
Quick release knives
Cuchillos de liberacion rapida
Schnellmesser



MODEL	 cm	 HP	 540 g/min 1000		 n°	 cm	 Kg	 Kg	 Kg
E300K	300	130-200	170/370	315	12	28	1550	1610	1850
E350K	350	150-230	170/370	315	14	28	1710	1650	1970
E400K	400	160-260	170/370	315	16	28	1930	1950	2240







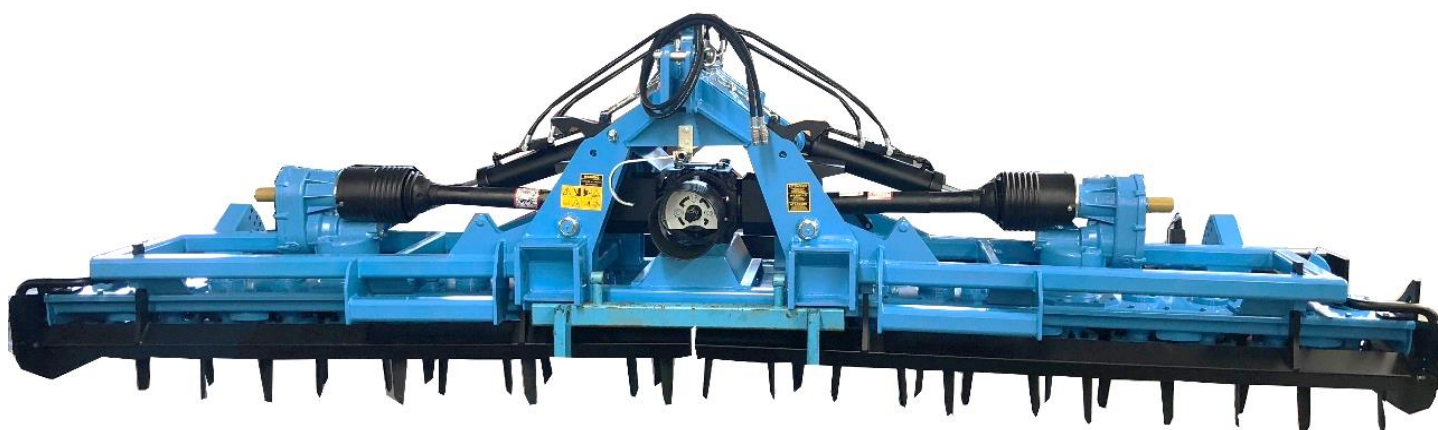

model AE - AR - AS - AK

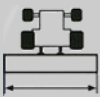
100-350 HP

- Barra livellatrice posteriore
- Parasassi anteriore e parapietre richiesta
- Rear levelling bar
- Front and rear stone guard required
- Barra de nivelación trasera
- Se requieren barandillas delanteras y de piedra
- Stahlzahnwelle
- Vorderer und hintere Steinschutz erforderlich
- Fiancate laterali oscillanti
- Larghezze di lavoro da 4 a 7 metri
- Tilting side panel
- Working widths from 4 to 7 meters
- Vial laterale oscillante
- Anchuras de trabajo desde 4 hasta 6 metros
- Hintere Rollenschnelleinstellung
- Arbeitsbreiten von 4 bis 6 Metern



model AE

MODEL	 cm	 HP	 540 g/min 1000		 n°	 cm	 Kg	 Kg	 Kg
A400E	400	100-140	221/305	410	16	25	1950	1960	2180
A500E	500	120-160	221/305	410	20	25	2200	2210	2550

model AR

A400R	400	140-160	221/305	410	16	25	2420	2450	2600
A500R	500	150-200	221/305	410	20	25	2620	2650	2780
A600R	600	180-260	221/305	410	24	25	2830	2850	3000

model AS

A400S	400	160-180	221/305	410	16	27	2720	2750	2900
A500S	500	180-230	221/305	410	20	27	2920	2950	3050
A600S	600	200-300	221/305	410	24	27	3130	3150	3300
A700S	700	240-350	221/305	410	28	27	3290	3300	3450

model AK

A500K	500	200-260	221/305	410	20	28	3240	3250	3450
A600K	600	220-320	221/305	410	24	28	3540	3550	3800
A700K	700	250-350	221/305	410	28	28	3750	3760	3990



Rulli-rollers



Rullo gabbia

Cage roller – Rodillo de barras - Stabwalze

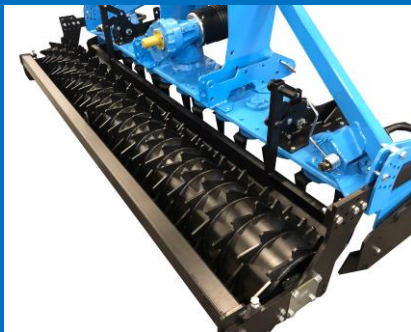

Rullo packer

Packer roller – Rodillo packer - Packerwalze



Rullo spuntoni

Spike roller – Rodillo con puntas - Zinkenwalze



Seminatrici - Seed drills - Sembradoras

